

# **Determination of low selenium concentrations by flow injection hydride generation atomic absorption spectrometry (FI-HG-AAS) - interference by perchloric acid**

Vera Galgan<sup>1</sup>, Adrian Frank<sup>2</sup>

<sup>1</sup> Department of Chemistry, National Veterinary Institute, SE-751 89 Uppsala, Sweden

<sup>2</sup> Division of Diagnostic Imaging and Clinical Pathology, Department of Biomedical Sciences and Veterinary Public Health, Faculty of Veterinary Medicine and Animal Sciences, Swedish University of Agricultural Sciences, P.O. Box 7038, SE-750 07 Uppsala, Sweden

## **Abstract**

In routine determinations of selenium (Se) by flow injection hydride generation atomic absorption spectrometry (FI-HG-AAS) technique a home-made equipment from commercially available components were used. An electrically heated quartz tube was used as atomiser. Blank and Se-standard solutions were analysed after wet digestion using an oxidising acid mixture (HNO<sub>3</sub>/HClO<sub>4</sub>). An absorption signal at 196.0 nm occurred in reagent blanks and disturbed Se measurements at low concentrations. Searching for the cause of this phenomenon was the purpose of the present work. Influencing factors on light absorption in the quartz tube were studied, which were gas flow rate and gas composition, acidity of carrier, blank- and Se-standard solutions, as well as presence of HClO<sub>4</sub> in the solutions. When the difference in acidity between carrier-, blank- and Se-standard solutions was eliminated, the gas flow stabilised resulting in disappearance of this effect. The main cause of this aberration was found in construction of the quartz tube that has been used in the system. The final detection limit achieved was in the range of 0.1-0.3 ng Se/ml measuring solution (0.3 ml injection volume) and was limited by the noise of the equipment.

## **Introduction**

The determination of total selenium (Se) in biological samples by hydride generation atomic absorption spectrometry (HG-AAS) assumes the complete destruction of the organic matter of the sample. However, acid-resistant organoselenium compounds such as selenomethione, selenocysteine and trimethyl-

selenonium-ion demand agents with high oxidation potential for complete destruction (Verlinden, 1982). Automated wet combustion using mixtures of nitric acid / perchloric acid ( $\text{HNO}_3$  /  $\text{HClO}_4$ ) (Frank, 1976, 1988; Galgan & Frank, 1988) or nitric acid / sulfuric acid / perchloric acid ( $\text{HNO}_3$  /  $\text{H}_2\text{SO}_4$  /  $\text{HClO}_4$ ) up to high temperatures are most successful procedures (Welz, Wolynetz & Verlinden, 1987). Dry ashing with magnesium nitrate has also been found to be an alternative to  $\text{HClO}_4$  (Hansson, Pettersson & Olin, 1987). Selenium compounds easily form volatile molecular species during decomposition, which can be lost e.g. by charring, or evaporation to dryness (Stanton, 1965; Gorsuch, 1970). In such cases residual  $\text{HClO}_4$  acid is necessary to retain Se in solution. Radio tracer studies (Gorsuch, 1959) using mixtures of  $\text{HNO}_3$  and  $\text{HClO}_4$  or that of  $\text{HNO}_3$ ,  $\text{H}_2\text{SO}_4$  and  $\text{HClO}_4$  gave good recoveries of Se. This is presumably related to the high boiling point of  $\text{HClO}_4$ , which ensures that oxidizing conditions of oxidizing-acid mixtures persist at all stages of the procedure.

Low Se concentrations (a few  $\mu\text{g}/\text{kg}$ ) in biological materials such as agricultural products like cereals, grass, and milk, as well as tissues of animal origin occur frequently in Sweden because of its Se-poor geological environment. Low Se-concentrations need for determination sensitive analytical methods with low limits of detection (LOD) resp. limits of quantitation (LOQ). For this purpose low reagent blanks are decisive.

Selenium in biological materials is analysed routinely at the Department of Chemistry, National Veterinary Institute, Uppsala. Selenium determination was performed by FI-HG-AAS under routine conditions (Galgan & Frank, 1988; 1993) using the AAS equipment from Varian (see instrumentation). The digested reagent blank caused an absorption signal corresponding to a LOD of 0.8 ng Se/ml measuring solution (mean blank + 3 SD). This means when samples of 5 g wet weight (wet wt.) or 1 g dry weight (dry wt.) were digested and diluted to 25 ml measuring solution a LOD corresponding to 0.004 mg Se/kg wet wt. or 0.020 mg Se/kg dry wt was obtained.

The aim of the present investigation was to study the nature of the absorption signal of the reagent blank, explain the cause of it and eliminate the signal for improvement of the LOD and LOQ in Se determination.

## **Materials and Methods**

### *Reagents*

Nitric acid ( $\text{HNO}_3$ ), 65% ; perchloric acid ( $\text{HClO}_4$ ), 70-72% ; hydrochloric acid ( $\text{HCl}$ ), 37% ; sulfuric acid ( $\text{H}_2\text{SO}_4$ ) 96 % all reagents of analytical grade (Merck, Germany).

Sodium tetrahydroborate ( $\text{NaBH}_4$ ), stable aqueous solution,  $12 \pm 0.5\%$  (g/v)  $\text{NaBH}_4$  in sodium hydroxide ( $\text{NaOH}$ ) solution,  $42 \pm 2\%$  (g/v)  $\text{NaOH}$  (Johnson Matthey GmbH, Alfa Products, Germany).

Selenium standard solution, selenous acid ( $\text{H}_2\text{SeO}_3$ ) 1000 mg/l (BDH, UK).

Ultra pure water, Milli-Q (MQ) ( $> 16$  Mohm/cm).

Argon, helium, hydrogen and nitrogen gas (AGA, Sweden).

### *Instrumentation*

Sample preparation:

Automated wet digestion system consisting of borosilicate glass tubes calibrated for 25 and 50 ml (total volume 80 ml) and an electrically heated block of aluminium connected to a microprocessor for control of temperature and time (Tecator Digestion System, model 40, and Autostep controller 1012, Tecator, Höganäs, Sweden), (Frank, 1976, 1988).

Flow-injection system consisting of:

Flow injection analyzer FIA-star -5020 Analyzer;

-5007 Auto sampler;

-5102-001 Injection valve "V-100";

-5020-032 Chemifold SR III;

PTFE reaction coils and connection tubes, 0.7 mm i.d. and 0.97 mm i.d. (Tecator AB, Höganäs, Sweden).

Connection tubes, 0.97 mm i.d and 1.7 mm i.d. (Habia, Teknofluor, Sweden)

Peristaltic-pump with 3 channels (Ventur Alitea AB, Sweden)

Pumping tubes, black/black, green/green, purple/purple (Elkay, Galway, Ireland).

Gas-liquid separator:

(GLS), modell 99-100402-00 (Varian, Australia).

Atomic absorption spectrometry equipment:

A) Atomic absorption spectrometer model AA-1475 (Varian, Australia),

Quartz tube (Varian, Australia): 4.5 mm i.d. for the 60 mm central part, 14.0 mm i.d. for the outer parts, total length ca. 170 mm, fused at the centre with a 1.4 mm i.d. quartz tube for gas inlet (Sturman, 1985) (Figure 1),

Selenium hollow cathode lamp (HCL) (Photron, Australia).

B) Atomic absorption spectrometer, model 403 (Perkin-Elmer, Norwalk, Connecticut, U.S.A),

Quartz tube according to Åström (1982): 6 mm i.d., length 170 mm, fused at the centre with a 1.3 mm i.d. quartz tube for gas inlet (Figure 1),

Selenium electrodeless discharge lamp (EDL) (Perkin-Elmer) with power-supply (Perkin-Elmer).

The operating conditions are described in Table 1.

The quartz tubes were heated in an electrically heated oven constructed according to Åström (1982).

Reduction and needle valves, flow meter (Brooks Instruments, Netherlands).

Computer: Commodore PC 20 (Germany) and printer.

Analogue chart recorder, 1 mV (BBC-Goerz Elektro GesmbH, Vienna, Austria).

## Procedure

### *Sample preparation*

Blank- and Se-standard solutions were digested in borosilicate glass tubes with 15 ml of a mixture of 65% HNO<sub>3</sub> and 70% HClO<sub>4</sub> (7:3 by vol.) in the automated wet digestion system. Time and temperature was controlled by the microprocessor according to a standard procedure (Frank, 1976, 1988). Reagent blanks and Se-standard solutions were treated in the same way. The last digestion step at 225°C was run no longer than 30 minutes to assure that an acid residue of HClO<sub>4</sub> remained in the tubes. After cooling to ambient temperature 10ml of 2.4 M (mol/l) HCl was added to each tube and Se was reduced from Se<sup>VI</sup> to Se<sup>IV</sup> by heating 30 minutes at 110°C (Norheim, 1986) according to equation ((1), Pettersson, 1990).

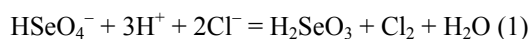

At ambient temperature the solutions were diluted to 25 ml with HCl in the same tubes according to

#### **measuring condition I:**

digested reagent blank- and Se-standard solutions were diluted with 2.4 M HCl, the carrier solution was 2.4 M HCl,

#### **measuring condition II:**

digested reagent blank- and Se-standard solutions were diluted with 5 M HCl, the carrier solution was 6.2 M HCl.

### *Hydride generation*

Seleniumhydrogen (SeH<sub>2</sub>) was generated by mixing 1.5% NaBH<sub>4</sub> solution in the FI-system with HCl as the carrier (according to equation (2), Welz & Sperling, 1999). Nitrogen as purge gas was introduced to the FI- system after the reaction-coil b (Fig. 1) and SeH<sub>2</sub> liberated from solution in the GLS. The scheme for the FI-system is shown in Figure 1. Operating conditions for the FI-system were 10s for sample injection time, 25s between two injections (rinse time 15s), 0.3 ml injection volume and peak height evaluation of the signal.

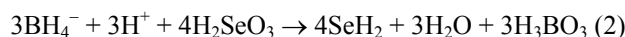

### *Atomic absorption spectrometry*

Seleniumhydrogen was transported from the GLS with nitrogen as purge gas to a quartz tube in an electrically heated oven. Atomisation was performed in the electrically heated quartz tube (equation (3) and (4), Dedina & Tsalev, 1995) at a temperature with maximum selenium absorption signal.

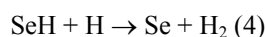
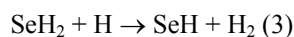

Selenium was determined at 196.0 nm using a hollow cathode lamp (HCL) for the Varian-instrument and an electrodeless discharge lamp (EDL) for the Perkin-Elmer (PE) instrument. For operating conditions see Table 1. To evaluate the signal from the instrument the atomic absorption spectrometer was connected to the FIA-instrument and simultaneously to an analogue chart-recorder. Selenium-concentration of the sample solution was calculated by the computing device of the FIA-instrument. Up to six standard concentration values could be entered. A linear or non-linear calibration graph could be chosen. The evaluation of the non-linear calibration graph is based upon the Lagrange interpolation theorem, which means that the bend of the calibration graph is taken into account. The digital values from the FIA-instrument were stored in the PC and Se concentrations in the sample were calculated and printed. The analogue signal from the AAS was simultaneously monitored on the chart-recorder for control and manual calculations.

### *Statistics*

For statistic evaluation the following programs were used:

Excel, Microsoft Office 2000, SR-1 Professional

Statgraphics® Plus, version 5 (Manugistics, Rockville, Maryland, U.S.A.)

## **Results and Discussion**

The following experiments were performed by using the AAS equipment and the quartz tube from Varian. As mentioned in the introduction the absorption signal from the digested reagent blank was high and limited determination of Se concentrations below 0.020 mg/kg when 1g dry material was digested. No more than 5g material (wet wt.) and 1g organic tissue (dry wt.) with a maximum amount of 500 mg fat is suitable for wet ashing with 15 ml oxidising acid mixture in the sample preparation procedure used in this work (Frank, 1976, 1988; Galgan & Frank, 1988).

### *Presentation of the problem*

Two series of calibration curves (Fig. 2, A and B) were prepared with reagent blank and Se-standard solutions from 0.4 to 8 ng/ml. For curve A aliquots of standard solutions were diluted with 2.4 M HCl the latter of which was also used as reagent blank. For curve B aliquots of standard and reagent blank solutions were digested according to the procedure, resulting in measuring solutions containing HClO<sub>4</sub> and 2.4 M HCl. Both series of solutions were analysed for Se-concentrations in the FI-HG-AAS-system according to measuring condition I.

The calibration curves are shown in Figure 2. For curve A a linear regression ( $y = 0.026x + 0.003$ ,  $R^2 = 0.9996$ ) was calculated. Calibration curve B, based on digested reagent blank and digested Se-standard solutions, showed a sigmoid curve fitting. Digested Se-standards had at higher Se-concentrations lower absorbance values than diluted standards. A striking difference between the calibration curves for diluted and digested standards occurred below 0.5 ng Se/ml.

Obviously the absorbance of the digested reagent blank revealed a positive value. The calibration curve did not pass the origin and had no intercept.

The absorbance of the digested reagent blanks was measured and found to be  $0.016 \pm 0.003$  ( $n=28$ ). Its magnitude corresponded to a value of  $0.5 \pm 0.08$  ng Se/ml calculated by using the absorbance signal from the Se-standard solution 0.8 ng/ml (curve B). Using measuring condition I according to calibration curve (B) selenium concentrations below 0.8 ng/ml (blank + 3 SD) were no longer detectable.

In a next experiment reagent blank, 0.4 and 0.8 ng Se/ml were digested and analysed (measuring condition I). The different absorbance signals are visualised by time-resolved chart recorder signals as shown in Figure 3 (a-c).

Figure 3 shows the shape of the absorbance signal of the reagent blank (a) and those of Se-standards of 0.4 and 0.8 ng/ml (b), respectively (c). Figure 3 (a) displays a rather symmetrical absorbance signal (one peak) where peak height occurs about 3 seconds (s) after injection of sample solution into the FI-system. Figures 3 (b) and 3 (c), however, display a double peak with a second peak height about 2 s later. The peak height of this second peak was increasing with increase of Se concentration in the standard solution, which indicated that the second peak height was caused by presence of Se and was proportional to the Se concentration of the standards.

The two peaks occurring at measurements, condition I, of digested blank/standard solutions were registered by a chart recorder with a speed of 60 cm/minute and their height evaluated graphically each in mm as shown in Figure 4. Curve A was constructed by measuring peak heights during the time from start of the absorbance signal to its return to baseline noise. Curve B shows the second peak height of the absorbance signal. Calculating Se-concentrations according to curve B values of 0.4 ng Se/ml and below were under the limit of detection. At increasing Se-concentrations (0.6 ng/ml) the second peak height became significantly higher than the first peak height and Se became detectable.

These observations were of great importance for understanding the difficulties in analysing Se-concentrations less than 0.8 ng Se/ml. The FI-instrument registered for each sample within a certain period of time the highest value of the absorbance signal from the AAS instrument. As far as the blank absorbance signal (single peak) was higher than that of the Se peak (second peak of the double peak), the instrument registered and calculated the highest signal as Se, which corresponded to about 0.4 – 0.5 ng Se/ml. That was in fact the signal of the digested reagent blank (Fig. 4, curve A).

#### *The cause of the blank absorption signal*

The AAS-signal described as the first peak, occurring independently of presence or absence of Se in reagent blank and standard solutions of low Se concentrations, limited the LOD of the method. Therefore, it was important to understand and search for the cause of this phenomenon. Interferences in determination of Se by

HG-AAS have been studied earlier. Several types of interferences are described in a review (Dedina & Tsalev, 1995).

#### Reagent blanks

Blank control and low Se concentrations in reagent blanks are reviewed by Dedina & Tsalev (1995). Piwonka et al. (1985) purified the reductant solution, as well as the acids employed in their system to decrease the reagent blanks to reach an LOD of 6 pg Se absolute. In the flow system described in this work NaBH<sub>4</sub> solution and HCl as carrier solution were running continuously through the flow system and zero setting to baseline noise of the AAS was possible. Flow injection of small blank amounts (0.3 ml in this work) is an advantage to continuous flow- and batch systems. Signals of the time resolved absorbance as mentioned above showed an earlier peak (first peak) for the blank than those for the Se-standard solutions.

#### Effect of nitrogen oxides

Nitrogen oxides have been reported to disturb the determination of Se by HG-AAS (Pettersson, 1990; Dedina & Tsalev, 1995; Welz & Sperling, 1999). In order to investigate whether traces of residual nitrous oxide gases might have caused the unspecific signal or not, five series of experiments with reagent blank solutions were performed. The solutions were digested according to the standard digestion procedure. The procedures were ended after keeping the solutions one hour at 180, 200, 220, 230 and 240°C. The digested reagent blanks were analysed according to measuring condition I and studied by evaluation of time-resolved absorbance signals on the paper of the chart recorder. Both peak heights in mm and in absorbance units of the AAS-signal were recorded. The results are compiled in Table 2.

In all 5 runs of the experiment the time-resolved recorder signals had the same symmetrical shape and position for peak height independently of the temperature of the last step of digestion. No double peak could be detected in this experiment. The peak heights expressed by both absorbance units and mm obviously were showing results of the same order of magnitude. Conclusively, no nitrous oxides were presumed to be the cause of the blank signal of the digested solutions.

#### Effect of spectral interferences

To exclude the possibility of any spectral interference (e.g. wing effect) at the wavelength of Se (196.0 nm) from e.g. hypothetical traces of boranes, the digested blank solution was studied by using a HCL lamp for Boron at 249.8 nm wavelength. Not even traces of Boron could be demonstrated. Consequently, no influence of wing effect could be suspected. A possible wing effect of N<sub>2</sub> gas at the 196.0 nm absorption line could be excluded, because changing N<sub>2</sub> purge gas to Argon gas the digested reagent blank still produced an absorbance signal.

Molecular gases like oxygen, carbon monoxide, carbon dioxide and other gases absorb at the Se 196.0 nm line (Dedina & Tsalev, 1995). In addition, degassing of the digested reagent blank and of the reagent solutions with nitrogen gas had no effect on the absorbance signal.

#### Effect of acidity

At the end of digestion according to the sample preparation procedure used in this work about 4.5 ml  $\text{HClO}_4$  (70-72%) were left in the digestion tubes. Therefore the effect of acid concentrations in the reagent blank on the first peak height was studied in the following experiment.

Solutions of  $\text{HClO}_4$  (70-72%), respectively  $\text{H}_2\text{SO}_4$  (96%) in increasing concentrations were prepared and injected (0.3 ml) into the carrier line (Table 3). Thus, 0.1, 1.0 and 4.0 ml of the acids, respectively, were diluted with MQ-water to 25 ml. For comparison also a digested reagent blank, consisting of 4.5 ml  $\text{HClO}_4$  and 20.5 ml 2.4 M HCl was included. The FI-instrument was run according to measuring condition I. The absorbance values are compiled in Table 3. The time-resolved signals were also evaluated manually on the recorder paper as peak heights (mm) and the corresponding time (s) of appearance of peak height.

At equal volume of  $\text{HClO}_4$  and  $\text{H}_2\text{SO}_4$  in the measuring solution  $\text{HClO}_4$  gave a higher absorbance signal than  $\text{H}_2\text{SO}_4$ . The absorbance was increasing with increased acid volume. Obviously the presence of strong acids was the cause of occurrence of a peak in the first peak position (Fig. 3) of the double peak and the peak height was influenced by the acid concentration and the strength of the acid. In this case  $\text{HClO}_4$  was the strongest acid, followed by HCl and  $\text{H}_2\text{SO}_4$ .

When a mixture of HCl and  $\text{HClO}_4$  of the same concentration as in digested sample solutions was run as carrier the first peak disappeared. However, the baseline noise increased enormously. Due to the obvious indications that  $\text{HClO}_4$  in the blank- and standard samples was the cause of occurrence of an unknown peak, which was eliminated when  $\text{HClO}_4$  was added to the carrier, the effect of acid strength in the carrier was studied in the followings.

Two different blank measuring solutions were prepared: digested reagent blank with an end volume of 4.5 ml  $\text{HClO}_4$  was diluted to 25 ml with a) 2.4 M HCl resulting in a calculated stoichiometric  $[\text{H}^+]$  concentration of 4.1 mol/l and b) 5.0 M HCl resulting in a calculated  $[\text{H}^+]$  of 6.2 mol/l. The interactive effect of different HCl concentrations in the carrier and different concentrations of  $\text{NaBH}_4$  solution was studied. As shown in Figure 5 the concentrations of HCl as carrier were 2.4, 4.1, 5.0 and 6.2 mol/l. Each of these solutions was also investigated at concentrations of 0.2, 0.5, 1.0, 1.5 and 2.0%  $\text{NaBH}_4$  solution. The peak heights were manually evaluated on the chart recorder as described above. By measuring each concentration several times ( $n =$  mostly 10) also confidence limits were calculated. The results of these observations are summarized in Figs. 5a, and 5b.

Figure 5a shows in general terms that increasing acid concentrations in the carrier decreases the peak height of the reagent blank. Also concentration of  $\text{NaBH}_4$



solution influences the peak height by displaying a maximum (of peak height) at approximately 1.5%.

In the second experiment shown by Fig. 5b, the conditions above were repeated, however, also the acid strength in the blank solution was increased. Residual 4.5 ml HClO<sub>4</sub> in the digested reagent blank was diluted with 5.0 M HCl. This change in general contributed to a further decrease of the peak height, which resulted in disappearance of the peak in the baseline noise at the highest HCl concentrations in the carrier solutions (5.0 M and 6.2 M) and at NaBH<sub>4</sub> concentrations  $\geq$  1.5%.

Conclusively, the investigations resulted in elimination of the unknown peak. The phenomenon evidently occurred because of a sudden injection of a rather concentrated acid blank solution of 0.3 ml into the carrier of the FI system and could be eliminated by increase of HCl-acidity in both the carrier and the blank solution.

#### *Influence of acid composition and gas flow rate on the absorbance*

The gas transported to the quartz tube (Varian) after hydride generation and gas liquid separation consisted of nitrogen purge gas, hydrogen and small amounts of oxygen dissolved in the solutions. Nitrogen gas introduction into the flow system and that of an additional help gas stream of N<sub>2</sub> gas through the GLS were controlled by needle valves (Fig. 1). Hydrogen was developed in steady state conditions when the alkaline NaBH<sub>4</sub> solution was introduced to the carrier. Different concentrations of HCl in carrier solution were applied. The evolution and yield of hydrogen was measured and shown to be constant, independent of molarity of HCl and responded for a 1.5% NaBH<sub>4</sub> solution to 25 ml/min that means 70 % of the calculated theoretical value. That was in agreement with the data in the literature where a yield of 70-80 % was described (Narsito, Agterdenbos & Santosa, 1990).

Before starting analysis, the electrically heated quartz tube was warmed up and equilibrated to working temperature under continuous N<sub>2</sub> gas flow. The light absorption increased asymptotically with increasing temperature as displayed by the AAS-instrument, from zero to 0.075 absorbance units at about 140 ml N<sub>2</sub> ml/min. The time for equilibration of the temperature was approximately 1 hour. Gas flow rate to the quartz tube and light absorption was tested under different experimental conditions in investigations I and II as follows.

#### Investigation I

Light absorption during N<sub>2</sub> gas flow alone and a mixture of (N<sub>2</sub> and H<sub>2</sub>) in the heated quartz tube was registered in absorbance units. For the experiment the T-piece g (Fig. 1) was used in the following way. One of the inlets ( $\alpha$ ) (0.7 mm i.d.) was used for inlet of N<sub>2</sub> gas and the other inlet ( $\beta$ ) (0.7 mm i.d.) for N<sub>2</sub> and/or H<sub>2</sub> gas. The third inlet (0.5 mm i.d.) was used as outlet ( $\gamma$ ) to calibrate the gas flow rates. After calibration the outlet ( $\gamma$ ) was connected with the heated quartz tube and the UV-absorption was measured. The gas flow rate through the T-piece was

calibrated by volume measurement at atmospheric pressure by using a volumetric gas bubble meter.

The gas inlet at ( $\alpha$ ) were set for constant  $N_2$  flow of 100 ml/min. Additional  $N_2$  and/or  $H_2$  was introduced through ( $\beta$ ). Sum of ( $\alpha$ ) and ( $\beta$ ) gives the total gas flow. The light absorption was determined by AAS after that light absorption in the quartz tube became stabilized. Gas flows and light absorptions in absorbance units are compiled in Table 4.

1. 100 ml  $N_2$  at inlet ( $\alpha$ ) and 20 ml  $N_2$  at ( $\beta$ ) were applied which gave together a total gas flow of 120 ml  $N_2$ /min. The absorbance signal registered at the display of the AAS was set to zero ( $\pm 0.000$ ).
2. When the gas flow at ( $\alpha$ ) was kept at 100 ml  $N_2$  /min and no gas was introduced at ( $\beta$ ) the light absorbance increased compared with 1. (+ 0.015).
3. When  $N_2$  at ( $\beta$ ) was replaced by  $H_2$  and the total gas flow was still kept at 120 ml/min ( $N_2$  83% by vol.) the absorbance signal decreased (compared with 1. (- 0.010)).
4. When  $N_2$  at ( $\alpha$ ) was restricted to 80 ml and 20 ml  $H_2$  was introduced at ( $\beta$ ) the total gas flow ( $N_2$  80% by vol.) was 100 ml/min and the light absorbance decreased compared with 2. ( $\pm 0.000$ ). Compared with experiment 1. no obvious change of absorbance was seen.

Summarising the experiments, decreased gas flow from 120 to 100 ml  $N_2$ /min increased the absorbance (1. & 2.). Unchanged total gas flow consisting of ( $N_2 + H_2$ ;  $N_2$ :83% and 80% by vol.) decreased the absorbance (1. & 3. and 2. & 4.).

#### Investigation II

Light absorption in the heated quartz tube was measured during  $N_2$  gas flow alone or a mixture of  $N_2$  and  $H_2$ , generated by the reaction of  $NaBH_4$  and different acid concentrations in the carrier solution. The flow system according to Figure 1 was used. The  $N_2$  gas flow was set to 144 ml/min before the pumps of the flow-system (filled with MQ-water) were started (stop flow) and was not changed during the experiments. Thereafter the pumps of the flow-system were started (flow on) and the gas flow rate was measured at atmospheric pressure directly at the outlet from the GLS by using a volumetric gas bubble meter. The GLS outlet was connected to the quartz tube and change of UV-absorption was followed until temperature equilibration of the tube. After temperature equilibrium was achieved the absorbance signal displayed on the AAS was set to zero ( $\pm 0.000$ ).

Two HCl concentrations (2.4 and 6.2 M HCl) were tested as carrier solutions with and without addition of conc.  $HClO_4$  to the solutions. The ratio of the acid solutions were 4.5 parts  $HClO_4$  to 21.5 parts HCl by volume. Milli-Q-water or 1.5%  $NaBH_4$  solution was introduced into the  $NaBH_4$ -line. The total gas flow rate, its calculated composition of  $N_2$  (difference between total gas flow and 25 ml  $H_2$ , see above) and light absorbance are compiled in Table 5.

Pumping MQ-water alone (Table 5.2) or MQ-water and HCl solutions of different concentrations (Table 5.3) resulted in decreased gas flow rate and increased absorbance. The concentration of HCl had no influence. Addition of conc. HClO<sub>4</sub> to HCl solutions in the carrier-line decreased gas flow rate and increased the absorbance. Introduction of NaBH<sub>4</sub> solution to the flow-system caused H<sub>2</sub> gas development, resulting in increased total gas-flow, diluted N<sub>2</sub> gas and decreased absorbance.

Nitrogen and hydrogen gas has different thermal conductivity properties. The thermal conductivity of H<sub>2</sub> gas at ambient temperature is about 7 times higher than that of N<sub>2</sub> gas. Partly replacement of N<sub>2</sub> gas with H<sub>2</sub> gas at constant total gas-flow will therefore have a cooling effect on the electrically heated quartz tube. Lower temperature of the quartz tube caused decreased light absorbance as was shown previously in investigations I and II.

### Investigation III

Addition of conc. HClO<sub>4</sub> to HCl solutions in the carrier-line decreased gas flow and increased absorbance (Table 5). Introduction of HClO<sub>4</sub> into the flow-system caused a violent reaction with NaBH<sub>4</sub> solution and the evolution of H<sub>2</sub> gas could even be observed in reaction coil c (Fig. 1). In order to test if introduction of purge gas through the T-piece (Fig. 1 g) into the flow-system was influenced by this violent reaction, N<sub>2</sub> gas was replaced with helium (He) gas. Helium is a gas with approximately 6 times higher thermal conductivity than N<sub>2</sub> gas. But the viscosity of He is about a factor 2.7 lower than that of N<sub>2</sub> gas. Thus, He has a higher flow rate than N<sub>2</sub> under the same pressure conditions.

The following experiment was performed. According to measuring condition I a digested blank, containing HClO<sub>4</sub>, was diluted with 2.4 M HCl and 2.4 M HCl was used as carrier solution. After introduction of NaBH<sub>4</sub> solution to the flow-system the He gas flow rate through the T-piece g (Fig. 1) into the flow-system was controlled with a flow meter calibrated with a bubble meter. Then 0.3 ml blank solution was injected to the flow-system and the He gas flow rate registered at the flow meter. Injection of a blank solution, containing HClO<sub>4</sub>, reduced He gas flow rate into the T-piece by nearly 80 % and the total flow-rate through the quartz tube by approximately 40 % resulting in simultaneously increased absorbance.

### *Comparison of two different quartz tubes*

The quartz tube of Varian, constructed particularly for Varian AAS instruments, was used for all experiments described above. The following investigations were performed to see if a double peak would occur when analysing a digested reagent blank with another type of quartz tube. Therefore a quartz tube according to Åström (1982) (Fig. 1) was tested in an AAS-instrument of PE using an EDL radiation source.

The change of tube and instrument displayed an unexpected effect namely the absence of the first peak. Digested reagent blank and Se-standard solutions were measured with 2.4 M HCl as carrier solution and 1.5% NaBH<sub>4</sub> solution using the

same FI-system as described above (Fig. 1). Under these conditions a digested reagent blank gave no detectable signal. However, Se-standards had the same sensitivity as compared with measurements performed with the quartz tube and AAS from Varian. Consequently, the different constructions of the two quartz tubes were decisive on the appearance or absence of a double peak analysing a reagent blank containing  $\text{HClO}_4$ . The experiments described above indicated that the electrically heated quartz tube from Varian was more sensitive for temperature changes than the electrically heated quartz tube constructed according to Åström (1982).

Sturman (1985) discussed the design of three different quartz tubes developed for analysing hydride forming elements with a Varian AAS-instrument. The quartz tubes were heated with a fuel-lean air-acetylene flame. He found that a T-shaped tube with 7 mm i.d. eliminated the problems of the swirling of the gas stream found with a larger tube with an internal diameter of 15 mm. But the percentage light transmission through the tube was unsatisfactory. A third quartz tube (Fig. 1 quartz absorption tube, Varian) was designed to minimize obstruction of the light beam and focus the light beam in the centre of the smaller part of the quartz tube resulting in improved percentage transmission.

#### *Limit of detection (LOD) and quantitation (LOQ)*

According to the International Union of Pure and Applied Chemistry (IUPAC) recommendations, LOD is the mean concentration of the blank plus three times its standard deviation. The LOD is the concentration at which we can decide with a reasonable certainty whether an element is present for a given analytical procedure or not. Quantitation is generally agreed to begin at a concentration equal to 10 standard deviations of the blank. This is called the limit of quantitation (LOQ), that means  $\text{LOQ} = 3.3 \text{ LOD}$  (Thomsen, Schatzlein & Mercurio, 2003).

Measurements of digested reagent blank- and Se-standard solutions, diluted with 2.4 M HCl and using 2.4 M HCl as carrier, resulted in a LOD of 0.8 ng Se/ml calculated by using absorbance values.

Digested reagent blank- and Se-standard solutions, diluted with 5 M HCl and using 6.2 M HCl as carrier, resulted in a LOD of 0.3 ng Se/ml calculated similarly as above (Fig. 6).

A further improvement of LOD, 0.1-0.2 ng Se/ml, was calculated from recorder signals and was limited by the noise of the HCL-lamp, the detector and the absorption of the atomiser atmosphere.

A control chart with signals in absorbance units ( $n=20$ ) of digested reagent blanks and digested (Se)-standard solutions (0.8 ng/ml) is shown in Fig. 6. Solutions were diluted with 5 M HCl and the carrier solution was 6.2 M. A blue line for the LOD (mean + 3 SD) of the digested reagent blanks and a red line (mean - 3 SD) of the Se-standard solutions are shown in the figure. The means and their confidence

level of about 90 % were clearly separated from each other. Consequently, Se was detectable (LOD) at a concentration of 0.3 ng/ml. The LOQ was 1 ng Se/ml.

### **Summary of results and comments**

A system for determination of the hydride-forming element Se, was presented by Galgan & Frank (1988). The purpose was to describe a simple equipment and method, which was easily built up by anyone using an AAS instrument and a FIA-system. All parts of the system were commercially available, both the GLS and the quartz tube by Varian. The electrically heated oven for heating of the quartz tube could be constructed at most laboratories. During meantime commercial available FI-HG-AAS instruments for determination of hydride forming elements have been developed.

By use of the described equipment routine determinations were performed. Analytical data of the method concerning sensitivity, detection limit and determinations in different matrices were also presented in 1988. At that time 2.4 M HCl was used as reagent blank, the same concentration as that of the carrier solution, and corresponded to the zero point of the calibration curve. During the routine work an absorbance signal was observed caused by the digested reagent blank, however, its cause was not understood.

The calibration curves (Fig. 2) were calculated from the absorbance signals of diluted Se-standard and digested Se-standard solutions. The latter had another slope and an appearance of sigmoid shape than that of the diluted standards. To find the cause for the aberration below 0.5 ng Se/ml from the usual form of calibration curve passing through the origin or having an intercept, investigations started when Se concentrations below 1 ng/ml measuring solution had to be determined. Thus, factors suspected to influence the analysis were systematically investigated in a tedious process as described in the experimental part. The changes in absorbance of the light beam in the quartz tube were monitored by time-resolved signals on a chart recorder. When running the digested reagent blanks an unspecific absorption peak was detected. However, studies of interacting factors described in the literature for hydride generation methods did not give any acceptable explanation for the peak that eventually was called 'ghost peak' (GP). Studies of time-resolved signals of the digested reagent blank and that of digested Se-standard solutions at low concentrations displayed that the GP was not identical with and clearly separated from the real Se-peaks.

The further efforts were directed to search for the cause of occurrence and control of the GP. When HClO<sub>4</sub> of same concentration as in the blank was added to the carrier the GP disappeared. Unfortunately the absorbance signals became very noisy excluding reliable measurements. To achieve complete destruction of organic biological materials use of HClO<sub>4</sub> is necessary. Obviously, acidity had some influence on occurrence of the GP. Thus, by increasing the HCl concentration both in the carrier and in digested reagent blank solution the GP could be controlled and eventually even disappeared in the background noise (Fig. 5b).

Still the cause of occurrence of the GP was not understood. Previously we noted increased UV light absorbance when heating the quartz tube under constant N<sub>2</sub> gas flow rate for equilibration of temperature before measurements. Increased gas flow rate reduced the light absorbance; decreased gas flow in opposite increased the absorbance signal. In the flow-system H<sub>2</sub> continuously was generated in steady state condition. Atomisation of SeH<sub>2</sub> was performed in a gas atmosphere containing both N<sub>2</sub> and H<sub>2</sub>. Nitrogen diluted with H<sub>2</sub> at the same total gas flow rate showed reduced absorbance due to higher thermal conductivity properties of H<sub>2</sub> than that of N<sub>2</sub>, which had a cooling effect on the electrically heated quartz tube. Lower temperature of the quartz tube decreased the absorbance as mentioned above (Table 4 and 5). Summarised, the light absorption in the heated tube was influenced by the gas flow rate and by the dilution of N<sub>2</sub> gas by H<sub>2</sub>.

Another important factor was the effect of acidity in the carrier solution influencing the N<sub>2</sub> gas flow rate under unchanged initial gas flow rate (Table 5). Consequently, the temperature and absorbance increased due to reduced gas flow rate. In routine measurements, HClO<sub>4</sub>-containing blank/samples, when injected into a carrier solution of 2.4 M HCl, caused sudden reduced purge gas flow rate. This resulted in increased temperature of the quartz tube and increased absorbance, until the blank/samples had passed the system. This effect was even more clearly demonstrated when He was used as purge gas.

## **Conclusions**

Evolution of H<sub>2</sub> gas was under steady state condition. Consequently, the temperature of the quartz tube remained unchanged. However, injecting blank/samples with high concentration of HClO<sub>4</sub> into the carrier solution caused instantaneous violent H<sub>2</sub> development decreasing temporarily the purge gas flow volume considerably. This caused temperature and absorbance increase-decrease in the quartz tube and in the UV light path, explaining the occurrence of the absorbance peak.

The absorbance peak was caused by the difference in acid strength between blank/sample solutions containing HClO<sub>4</sub> and carrier solution. Increasing the HCl concentration of the carrier solution and optimising the HCl concentration in blank/sample solutions resulted in control and even disappearance of the peak.

The final detection limit achieved was in the range of 0.1-0.3 ng Se/ml measuring solution (0.3 ml injection volume) and was limited by the noise of the equipment.

## **Acknowledgements.**

The authors want to thank Roland Pettersson, Ph.D., Senior Lecturer at the Department of Physical and Analytical Chemistry, Analytical Chemistry, Uppsala University, for interest, advice and fruitful discussions.

## References

- Åström, O. 1982. Flow injection analysis for the determination of bismuth by atomic absorption spectrometry with hydride generation. *Analytical Chemistry* 54, 190-193.
- Dedina, J. & Tsalev, D.L. 1995. Hydride generation atomic absorption spectrometry. In: *Chemical analysis. A Series of Monographs on Analytical Chemistry and its Application*. (Eds. J.D. Winefordner & I.M. Kolthoff). John Wiley & Sons Ltd. Chichester. Volume 130.
- Frank, A. 1976. Automated wet ashing and multi-metal determination in biological materials by atomic absorption spectrometry. *Fresenius Zeitschrift für Analytische Chemie* 279, 101-102.
- Frank, A. 1988. Semi-micro accessory to an automated wet digestion system for ashing small sample amounts. In: *Trace Element Analytical Chemistry in Medicine and Biology*. (Eds. P. Brätter & P. Schramel). Walter de Gruyter & Co, Berlin, New York, Volume 5, pp 78-83.
- Galgan, V & Frank A. 1988. Automated system for determination of selenium in biological materials. In: *Trace Element Analytical Chemistry in Medicine and Biology*. (Eds. P. Brätter & P. Schramel). Walter de Gruyter & Co, Berlin, New York, Volume 5, pp 84-89.
- Galgan, V. & Frank, A. 1993. Notes and comments on the determination of selenium in biological materials. *Norwegian Journal of Agricultural Sciences*, Supplement, 11, 57-74.
- Gorsuch, T.T. 1959. Radiochemical investigations on the recovery for analysis of trace elements in organic and biological materials. *Analyst* 84, 135-173.
- Gorsuch, T.T. 1970. *The destruction of organic matter*. 1<sup>st</sup> edition. Braunschweig Pergamon Press Ltd. Oxford, New York, Toronto, Sydney 152 pp.
- Hansson, L., Pettersson, J. & Olin, Å. 1987. A comparison of two digestion procedures for the determination of selenium in biological material. *Talanta* 34, 829-833.
- Narsito, Agterdenbos, J. & Santosa, S.J. 1990. Study of processes in the hydride generation atomic absorption spectrometry of antimony, arsenic and selenium. *Analytica Chimica Acta* 237, 189-199.
- Norheim, G. & Haugen, A. 1986. Precise determination of selenium in tissues using automated wet digestion and an automated hydride generator-atomic absorption spectroscopy system. *Acta Pharmacologica and Toxicologica* 59, Suppl. 7, 610-612.
- Pettersson, J. 1990. A hydride generation atomic absorption apparatus for the determination of selenium with some applications. *Dissertation*, Uppsala. ISBN: 91 554 2531 3.
- Pettersson, J., Hansson, L. & Olin, Å. 1986. Comparison of four digestion methods for the determination of selenium in bovine liver by hydride generation and atomic-absorption spectrometry in a flow system. *Talanta* 33, 249-254.
- Piwonka, J., Kaiser, G. & Tölg, G. 1985. Determination of selenium at ng/g- and pg/g-levels by hydride generation-atomic absorption spectrometry in biotic materials. *Fresenius Zeitschrift für Analytische Chemie*. 321, 225-234.
- Stanton, R.E. & McDonald, A.J. 1965. The determination of selenium in soils and sediments with 3,3'-Diaminobenzidine. *Analyst* 90, 497-499.
- Sturman, B.T. 1985. Development of a continuous-flow hydride and mercury vapor generation accessory for atomic absorption spectrometry. *Applied Spectroscopy*. 39, 48-56.
- Thomsen, V., Schatzlein, D. & Mercurio, D. 2003. Limits of detection in spectroscopy. *Spectroscopy* 18, 112-114.
- Verlinden, M. 1982. On the acid decomposition of human blood and plasma for the determination of selenium. *Talanta* 29, 875-882.
- Welz, B., Wolynetz, M.S. & Verlinden, M. 1987. Inter-laboratory trial on the determination of Se in lyophilized human blood serum, blood and urine using HGAAS. *Pure and Applied Chemistry* 59, 927-936.
- Welz, B. & Sperling, M. 1999. *Atomic absorption spectrometry*. 3<sup>rd</sup> edition. Wiley-VCH. Weinheim, New York. 941 pp.

## Tables

**Table 1.** Operating conditions for AAS

Instrument	A) Varian AA-1475	B) PE 403
Wavelength	196.0 nm	196.0 nm
Slit	1 nm	2 nm
Evaluation	peak height	peak height
Integration time	1 sec	1 sec
Background corrector	Off	
Double beam mode	Yes	yes
Radiation source	HCL	EDL
Lamp current	8 mA	6 W

**Table 2.** Digestion of reagent blanks at different temperatures of the last digestion step, duration one hour. The peak-height of reagent blank signals is expressed in absorbance units and in arbitrary units (mm). The values are means of two measurements.

Temperature °C	peak-height absorbance	peak-height mm
180	0.013	43
200	0.016	50
220	0.015	46
230	0.015	46
240	0.016	48



**Table 3.** Diluted solutions of HClO<sub>4</sub> (70-72%) and H<sub>2</sub>SO<sub>4</sub> (96%) in increasing concentrations as well as a digested reagent blank were injected into the carrier line under measuring condition I. The absorbance signals (mean, n=5) registered in absorbance units and on chart recorder (peak height in mm and appearance in time (s)) are compiled.

acid solution	absorbance (peak height)	recorder signal	
		peak height (mm)	appearance in time (s)
0.1ml HClO <sub>4</sub> + 24.9ml MQ-water	0.003	14	(2.1)
1ml HClO <sub>4</sub> + 24ml MQ-water	0.009	38	(2.9)
4ml HClO <sub>4</sub> + 21ml MQ-water	0.012	49	(3.1)
0.1ml H <sub>2</sub> SO <sub>4</sub> + 24.9ml MQ-water	baseline noise	baseline noise	
1ml H <sub>2</sub> SO <sub>4</sub> + 24ml MQ-water	0.003	14	(2.7)
4ml H <sub>2</sub> SO <sub>4</sub> + 21ml MQ-water	0.006	23	(3.2)
reagent blank 4.5ml HClO <sub>4</sub> + 20.5ml 2.4M HCl	0.016	66	(4.3)

**Table 4.** Light absorption of N<sub>2</sub> gas alone and mixtures of N<sub>2</sub> and H<sub>2</sub> in the heated quartz tube determined by AAS at 196.0 nm and compiled in absorbance units.

	ml/min		N <sub>2</sub> %	absorbance
	(α=N <sub>2</sub> )	(β)		
1.	100	+ 20 N <sub>2</sub>	100	± 0.000
2.	100		100	+ 0.015
3.	100	+ 20 H <sub>2</sub>	83	- 0.010
4.	80	+ 20 H <sub>2</sub>	80	± 0.000

**Table 5.** Absorbance (abs.) in the heated quartz tube was measured during N<sub>2</sub> gas flow alone or a mixture of (N<sub>2</sub> and H<sub>2</sub>), generated by the reaction of NaBH<sub>4</sub> and different acid concentrations in the carrier solution. Two HCl concentrations (2.4 and 6.2 M HCl) were tested as carrier solutions without and with conc. HClO<sub>4</sub> added to the carrier solutions. The ratio of the acid solutions was 4.5 parts HClO<sub>4</sub> to 21.5 parts HCl. Milli-Q-water (MQ) or 1.5% NaBH<sub>4</sub> solution was introduced into the NaBH<sub>4</sub>-line. The total gas flow, its calculated composition of N<sub>2</sub> (difference between total gas flow and 25 ml H<sub>2</sub>, see above) and light absorbance are compiled

(a) stop-flow of the pumps; (b) flow on of the pumps

	carrier-line	NaBH <sub>4</sub> -line	gas flow (total) ml/min	N <sub>2</sub> (ml/min)	H <sub>2</sub> (ml/min)	mean abs.
1 <sup>a</sup>	MQ-water	MQ	144	144		0.000
2 <sup>b</sup>	MQ-water	MQ	109	109		0.016
3 <sup>b</sup>	2.4 M HCl	MQ	108	108		0.015
	6.2 M HCl	MQ	108	108		0.016
4 <sup>b</sup>	2.4 M HCl + HClO <sub>4</sub>	MQ	98	98		0.021
	6.2 M HCl + HClO <sub>4</sub>	MQ	101	101		0.021
5 <sup>b</sup>	2.4 M HCl	NaBH <sub>4</sub>	131	106	25	0.002
	6.2 M HCl	1.5 %	133	108	25	0.002
6 <sup>b</sup>	2.4 M HCl + HClO <sub>4</sub>	NaBH <sub>4</sub>	124	99	25	0.003
	6.2 M HCl + HClO <sub>4</sub>	1.5 %	127	102	25	0.003

## Figures

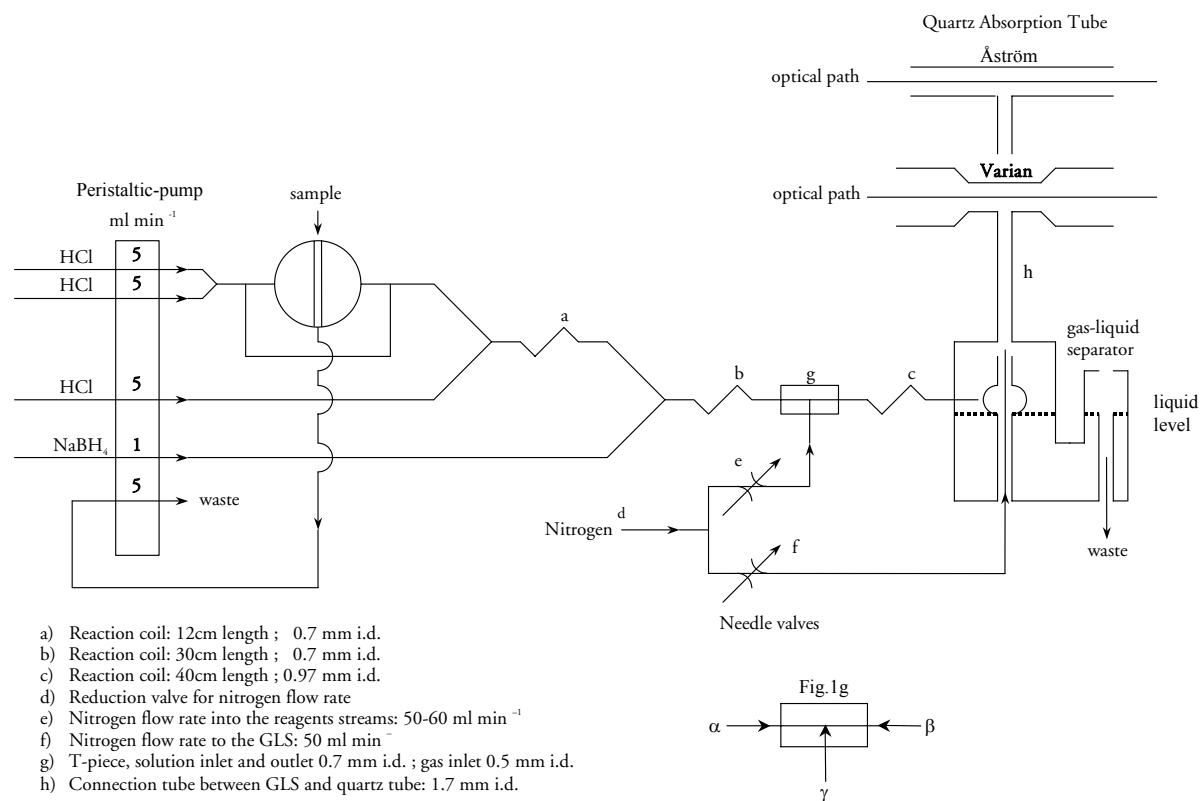

**Fig. 1.** Flow injection manifold for selenium determination by hydride generation and atomic absorption spectrometry (FI-HG-AAS). The design of the quartz absorption tubes of Varian and Åström was as follows:

**Varian** - Quartz tube according to Sturman (1985): 4.5 mm i.d. for the 60 mm central part, 14.0 mm i.d. for the outer parts, total length ca. 170 mm, fused at the centre with a 1.4 mm i.d. quartz tube for gas inlet.

**Åström** - Quartz tube according to Åström (1982): 6 mm i.d., length 170 mm, fused at the centre with a 1.3 mm i.d. quartz tube for gas inlet.

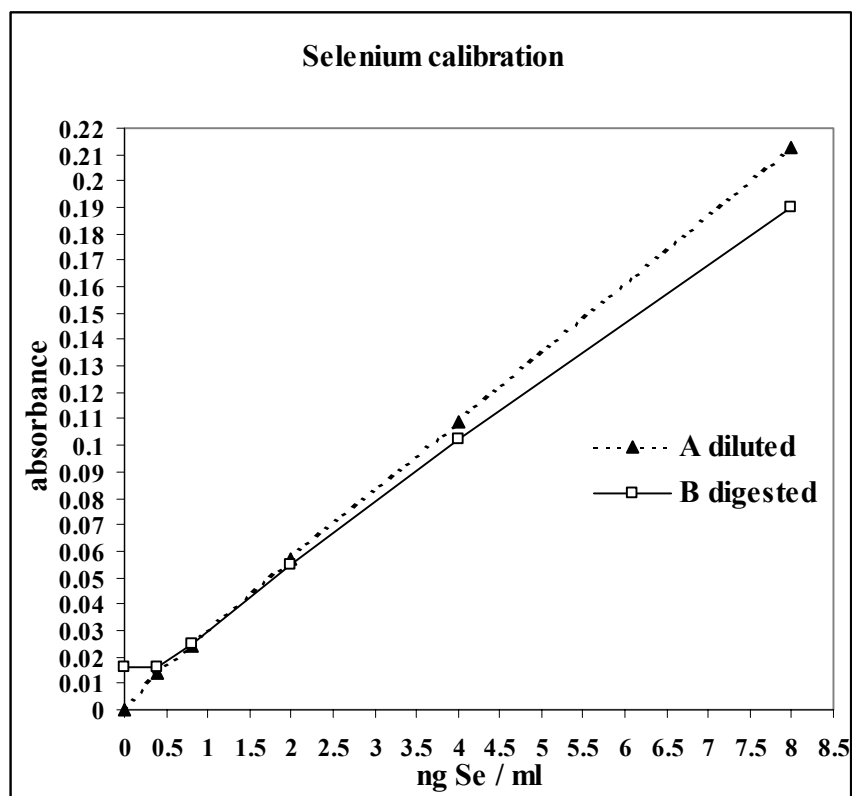

**Fig. 2.** Selenium (Se) calibration curves based on:  
**A:** standard solutions from 0.0 – 8.0 ng Se/ml in 2.4 M HCl, 0.0 ng Se/ml was used as reagent blank.  
**B:** digested Se-standard solutions from 0.0 – 8.0 ng Se/ml containing HClO<sub>4</sub> and 2.4 M HCl, 0.0 ng Se/ml was used as reagent blank.  
 Both series of solutions were analysed for Se-concentrations in the FI-HG-AAS-system according to measuring condition I.  
 For curve A a linear regression ( $y = 0.026x + 0.003$  ;  $R^2 = 0.9996$ ) was calculated.

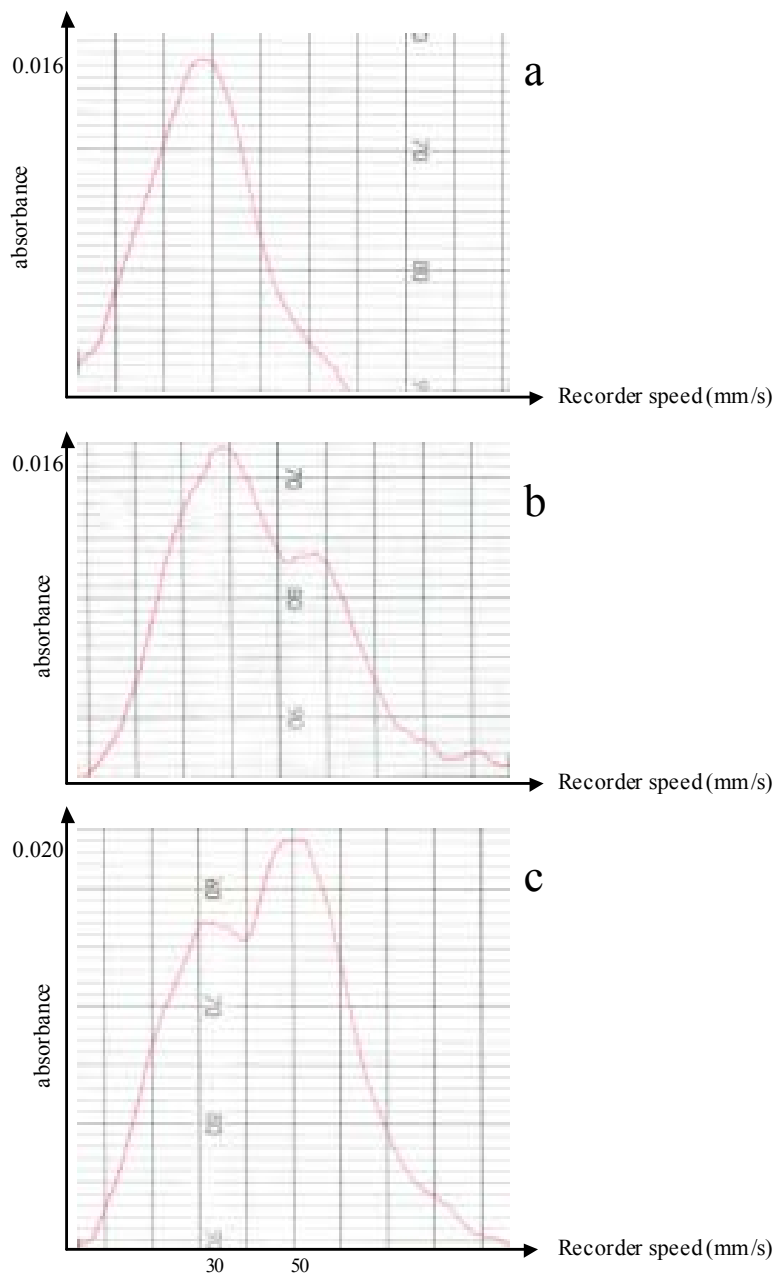

**Fig. 3.** Time resolved chart recorder absorbance signal for a = digested reagent blank, b = digested Se-standard, 0.4 ng/ml and c = digested Se-standard, 0.8 ng/ml (measuring condition I).

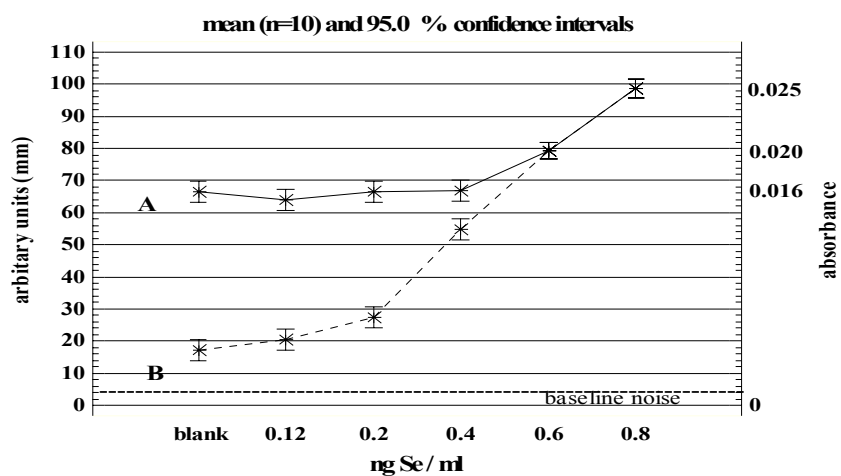

**Fig. 4.** The two peaks occurring at measurements, condition I, of digested blank/standard solutions were registered by a chart recorder with a speed of 60 cm/minute and their height evaluated graphically each in mm as shown in the figure. Curve A was constructed by measuring peak heights during the time from start of the absorbance signal to its return to baseline noise. Curve B shows the second peak height of the absorbance signal.

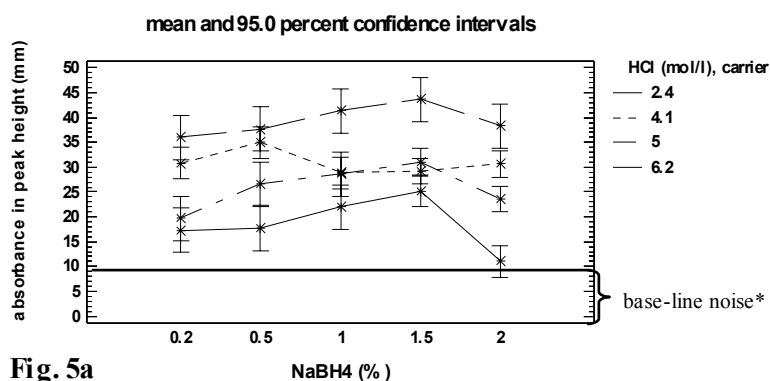

Fig. 5a

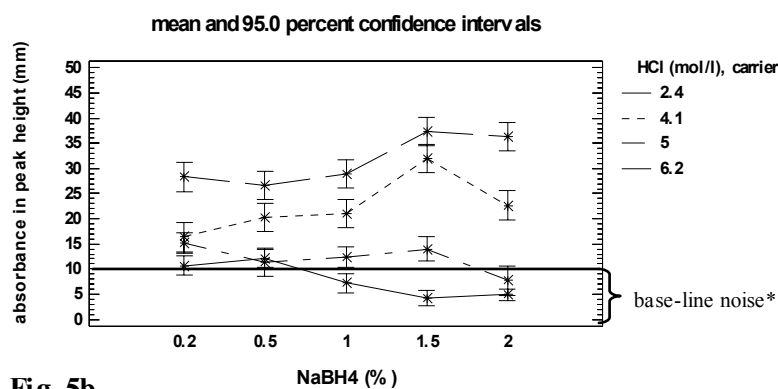

Fig. 5b

**Fig. 5.** The absorbance signal in peak height produced of reagent blanks (series Fig. 5a and Fig. 5b) at different HCl concentrations in the carrier and continuous flow of different NaBH<sub>4</sub>-concentrations were registered on a chart recorder in mm units. The digested reagent blanks, end volume 4.5 ml HClO<sub>4</sub>, were reduced and diluted to 25 ml with

**a** (Fig. 5a) 2.4 M HCl resulting in a calculated stoichiometric [H<sup>+</sup>] of 4.1 mol/l and

**b** (Fig. 5b) 5.0 M HCl resulting in a calculated stoichiometric [H<sup>+</sup>] of 6.2 mol/l.

\* base-line noise: mean + 3 SD (n=21)

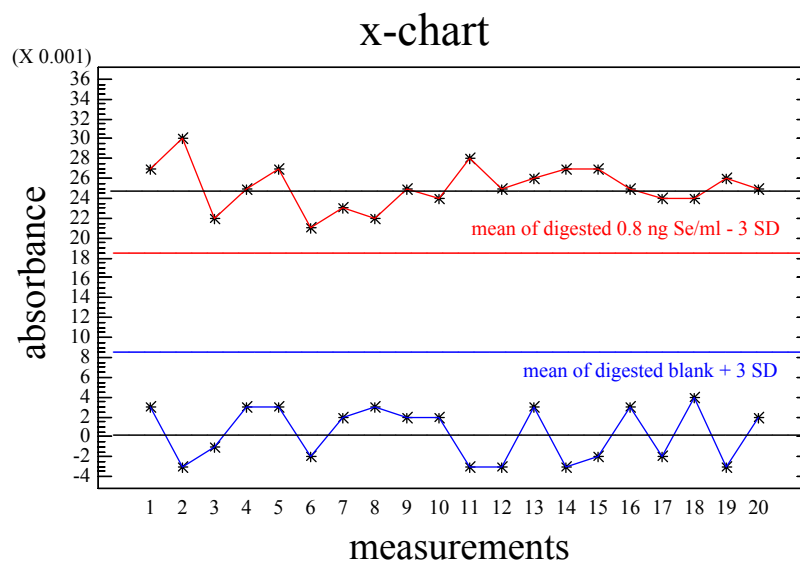

**Fig. 6.** A control chart with signals in absorbance units ( $n=20$ ) of digested reagent blanks and digested (Se)-standard solutions (0.8 ng/ml) is shown in the figure. Solutions were diluted with 5 M HCl and the carrier solution was 6.2 M. A blue line for the LOD (mean + 3 SD) of the digested reagent blanks and a red line (mean - 3 SD) of the Se-standard solutions are shown in the figure.